

Technical Information — Sizes

VersaEdge – Standard

The Standard VersaEdge Stair Nose combines style and function to enhance the beauty of a staircase or step. For use on flooring with an overall thickness of up to 19 mm (0.75").

Surface Material: High Wear Resistant Aluminum Oxide Laminate

Core Material: PVC

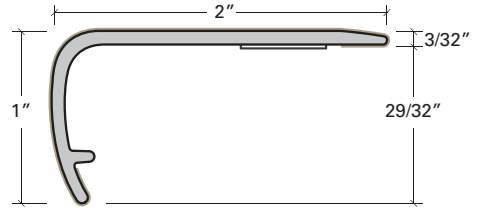

Installation

“Lock-Down” Install (e.g. Stair Treads)

Laminate/Vinyl/Hardwood/
Engineered Wood

Vinyl/LVT
Alternative Flush

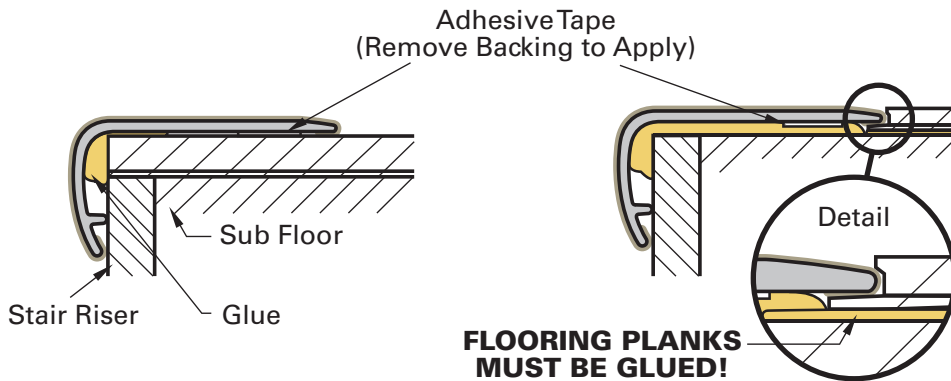

“Floating” Install

Laminate/
Engineered Wood

Vinyl/LVT

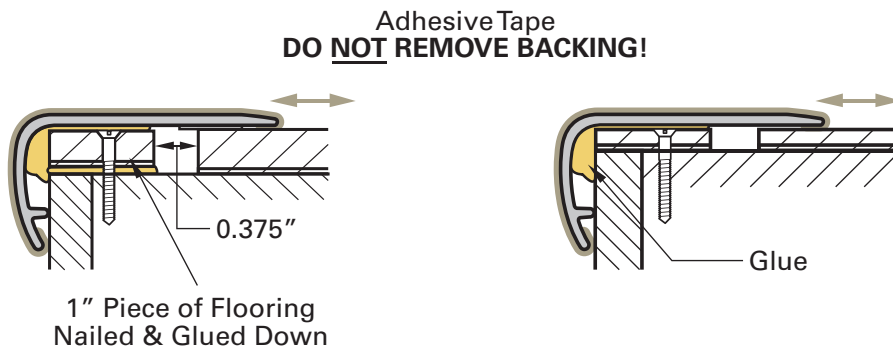

VersaEdge Stair Nose

“Lock-Down” Installation

Flooring with an overall thickness of up to 19 mm (0.75")

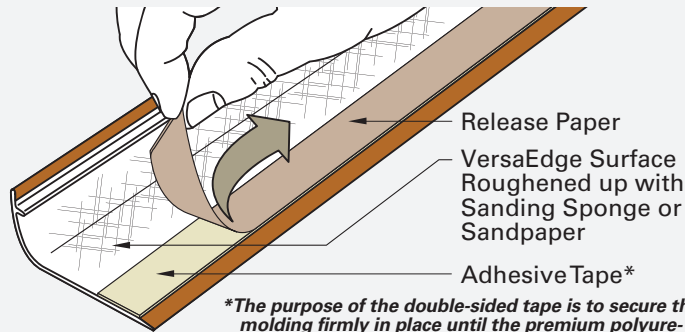
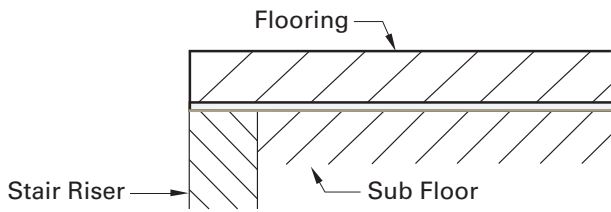

*The purpose of the double-sided tape is to secure the molding firmly in place until the premium polyurethane construction adhesive totally cures.

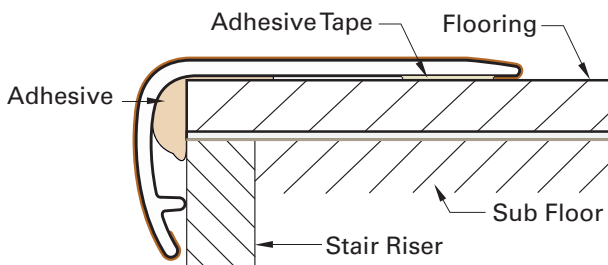
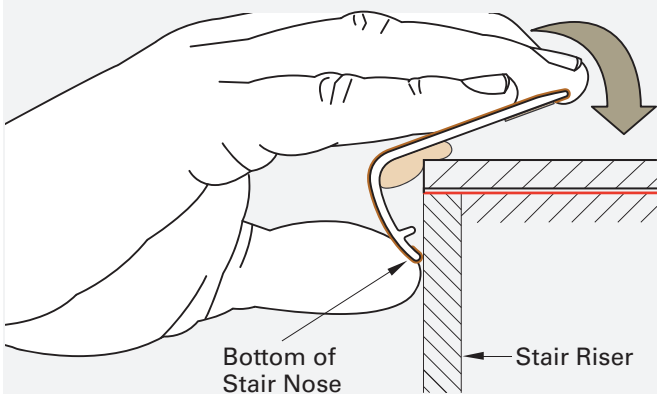
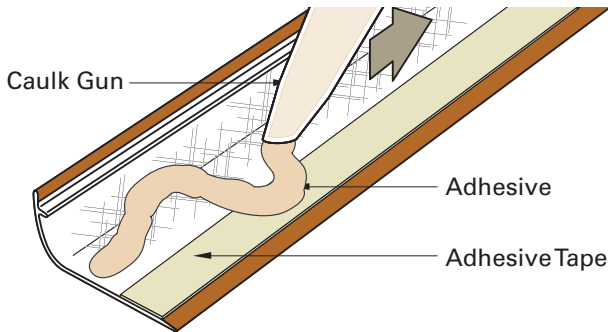

Step 1

Install the riser flush to the stair. Glue down flooring planks (for more details see manufacturers recommendations). Then, clean flooring and molding as directed below:

CLEANING PREPARATION FOR BOTH SURFACES

Preparing the floor & molding as outlined is mandatory to achieve the required bonding strength

1. Use a damp cloth (water only) to clean both surfaces of loose particles or surface films.
2. Roughen the surfaces with sandpaper (100-150 grit), sanding sponge or metal brush. For flooring, only roughen up area that will be covered (1.25" to 1.5").
3. Degrease both surfaces to remove all traces of oil, grease, dust, and fingerprints by using a solvent such as methyl ethyl ketone (MEK), acetone or isopropyl alcohol.
4. Let both surfaces dry thoroughly before applying adhesive.

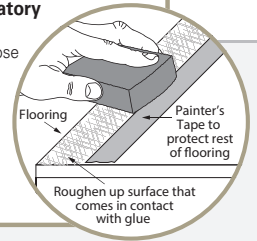

Step 2

Turn VersaEdge over and roughen the inside surface of the VersaEdge to increase bond by means of 60 grit sandpaper, sanding sponge, or a metal brush. Then, gently peel the release paper all the way off the adhesive tape.

Step 3

Next, apply a generous bead of a **Premium Polyurethane Construction Adhesive** along the entire inside corner. **Be sure to overlap the tape with the adhesive**

Underside of molding generously covered with adhesive

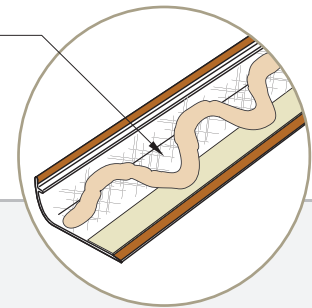

Step 4

Touch the bottom of molding to the stair riser and carefully roll the stair nose in place. Make any final adjustments before you push the molding all the way down. Once it's in the final position, press down firmly with your hands and make your way down the entire stair nose. It may take 2 or 3 passes to set it firmly in place.

Step 5

Let the adhesive cure for at least 4 hours before any walking on it. For exposure to full traffic, wait 24 to 48 hours.

NOTE: Complete cure takes 48 hours.

VersaEdge Stair Nose

“Floating” Installation

Flooring with an overall thickness of up to 19 mm (0.75”)

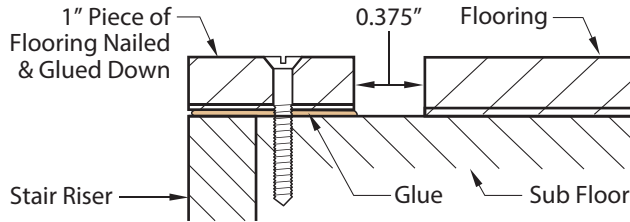

Step 1

Install the riser flush to the stair. Cut a 1” wide strip of your floor. Drill, counter-sink, screw and glue it flush to the stair riser. Install flooring 0.375” from the glued down 1” strip. **DO NOT glue flooring down.** Clean flooring and molding as directed below:

CLEANING PREPARATION FOR BOTH SURFACES

Preparing the floor & molding as outlined is mandatory to achieve the required bonding strength

1. Use a damp cloth (water only) to clean both surfaces of loose particles or surface films.
2. Roughen the surfaces with sandpaper (100-150 grit), sanding sponge or metal brush. For flooring, only roughen up area that will be covered (1.25” to 1.5”).
3. Degrease both surfaces to remove all traces of oil, grease, dust, and fingerprints by using a solvent such as methyl ethyl ketone (MEK), acetone or isopropyl alcohol.
4. Let both surfaces dry thoroughly before applying adhesive.

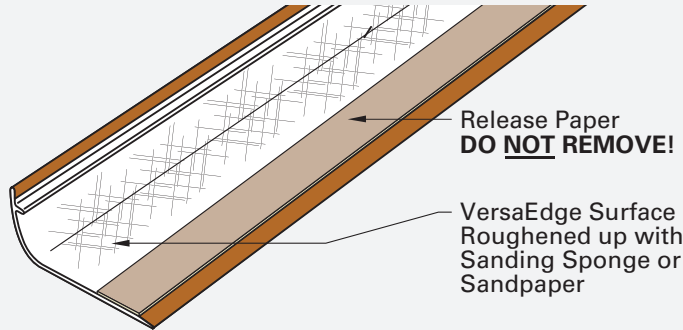
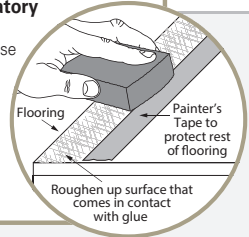

Step 2

Turn VersaEdge after following the cleaning preparation above. **DO NOT peel the release paper off the adhesive tape.**

Step 3

Next, apply a generous bead of a **Premium Polyurethane Construction Adhesive** along the entire inside corner. **Be sure to NOT to overlap the tape with the adhesive.**

Underside of molding generously covered with adhesive

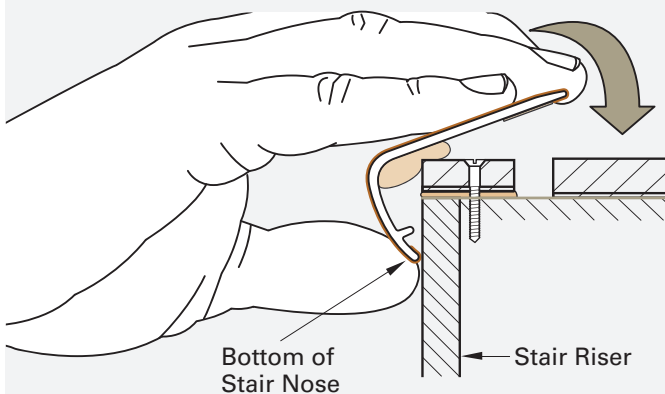
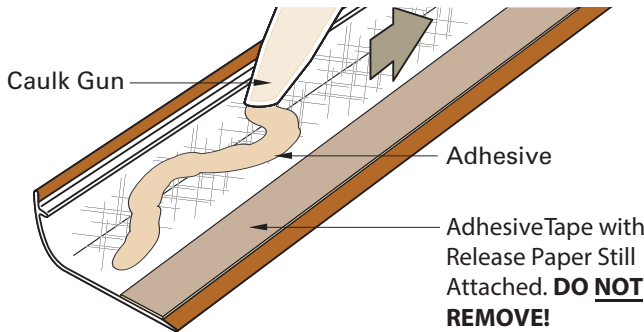
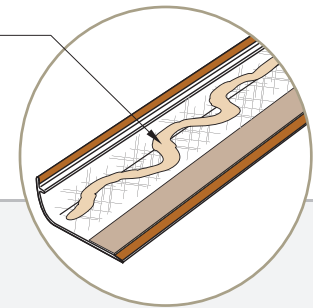

Step 4

Touch the bottom of molding to the stair riser and carefully roll the stair nose in place. Make any final adjustments before you push the molding all the way down. Once it's in the final position, press down firmly with your hands and make your way down the entire stair nose. It may take 2 or 3 passes to set it firmly in place.

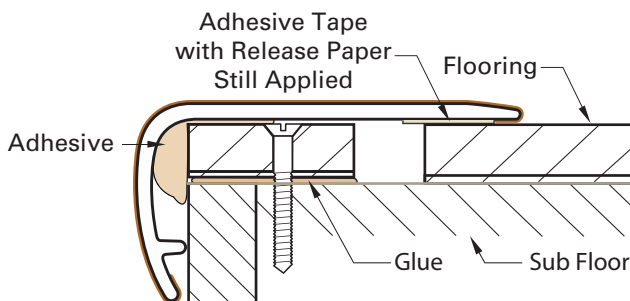

Step 5

Let the adhesive cure for at least 4 hours before any walking on it. For exposure to full traffic, wait 24 to 48 hours.

NOTE: Complete cure takes 48 hours.

VersaEdge Stair Nose

Installation on 2mm LVT flooring

“Flush Lock-Down” Installation

Flooring with an overall thickness of

2
mm

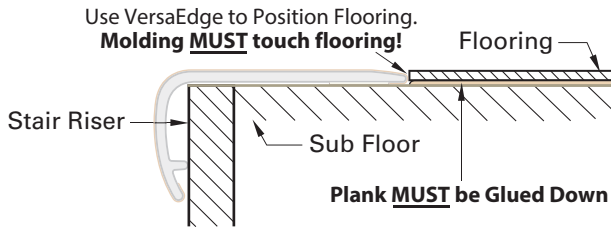

Step 1

Install the riser flush to the stair. Use VersaEdge to determine where to start your flooring. VersaEdge must fit snugly next to plank. Remove VersaEdge and **glue the flooring plank down**. Clean flooring and molding as directed below:

CLEANING PREPARATION FOR BOTH SURFACES

Preparing the floor & molding as outlined is mandatory to achieve the required bonding strength

1. Use a damp cloth (water only) to clean both surfaces of loose particles or surface films.
2. Roughen the surfaces with sandpaper (100-150 grit), sanding sponge or metal brush. For flooring, only roughen up area that will be covered (1.25" to 1.5").
3. Degrease both surfaces to remove all traces of oil, grease, dust, and fingerprints by using a solvent such as methyl ethyl ketone (MEK), acetone or isopropyl alcohol.
4. Let both surfaces dry thoroughly before applying adhesive.

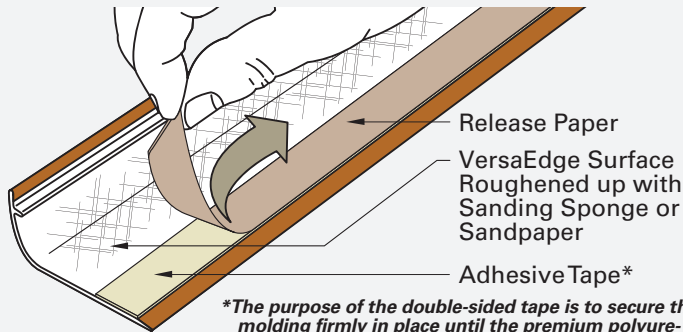
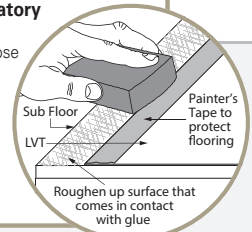

Step 2

Turn VersaEdge over and roughen the inside surface of the VersaEdge to increase bond by means of 60 grit sandpaper, sanding sponge, or a metal brush. Then, gently peel the release paper all the way off the adhesive tape.

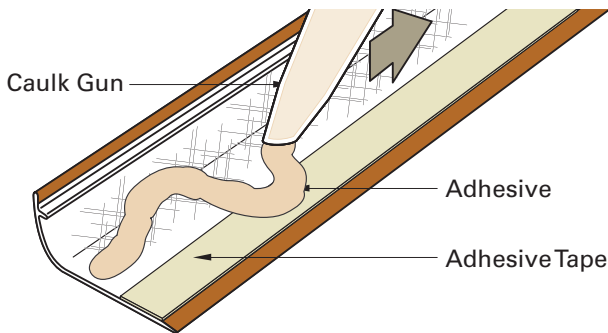

Step 3

Next, apply a generous bead of a **Premium Polyurethane Construction Adhesive** along the entire inside corner. **Be sure to overlap the tape with the adhesive**

Underside of molding generously covered with adhesive

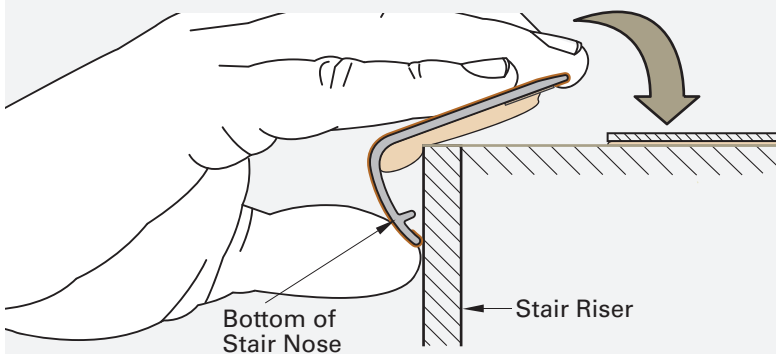
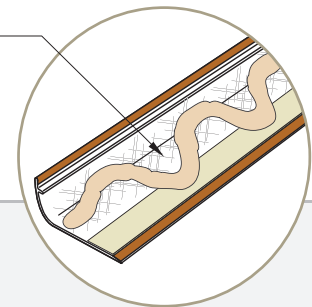

Step 4

Touch the bottom of molding to the stair riser and carefully roll the stair nose in place. Make any final adjustments before you push the molding all the way down. Once it's in the final position, press down firmly with your hands and make your way down the entire stair nose. It may take 2 or 3 passes to set it firmly in place.

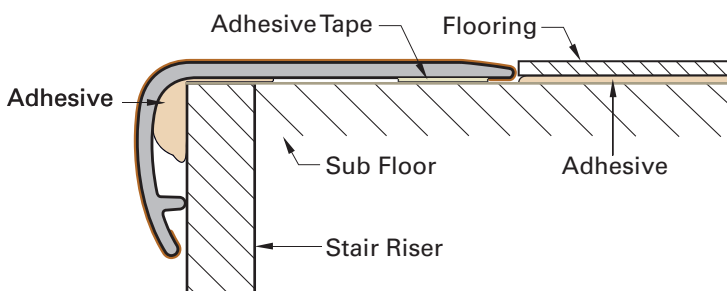

Step 5

The tape may not sufficiently adhere to the rougher stair or subfloor surfaces. **Allow at least 24 hours for the construction adhesive to form a bond.** You should always start at top of stairs and work your way down to avoid contact with the installed moldings until cured.

NOTE: Complete cure takes 48-72 hours.

VersaEdge Stair Nose

Installation on 3mm LVT flooring

“Flush Lock-Down” Installation

Flooring with an overall thickness of

3
mm

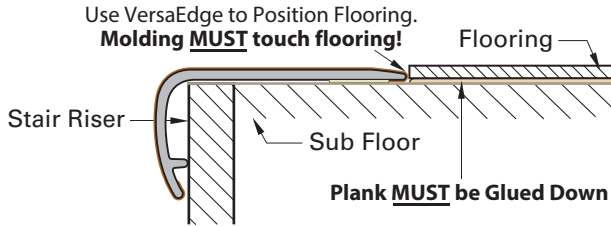

Step 1

Install the riser flush to the stair. Use VersaEdge to determine where to start your flooring. VersaEdge must fit snugly next to plank. Remove VersaEdge and **glue the flooring plank down**. Clean flooring and molding as directed below:

CLEANING PREPARATION FOR BOTH SURFACES

Preparing the floor & molding as outlined is mandatory to achieve the required bonding strength

1. Use a damp cloth (water only) to clean both surfaces of loose particles or surface films.
2. Roughen the surfaces with sandpaper (100-150 grit), sanding sponge or metal brush. For flooring, only roughen up area that will be covered (1.25" to 1.5").
3. Degrease both surfaces to remove all traces of oil, grease, dust, and fingerprints by using a solvent such as methyl ethyl ketone (MEK), acetone or isopropyl alcohol.
4. Let both surfaces dry thoroughly before applying adhesive.

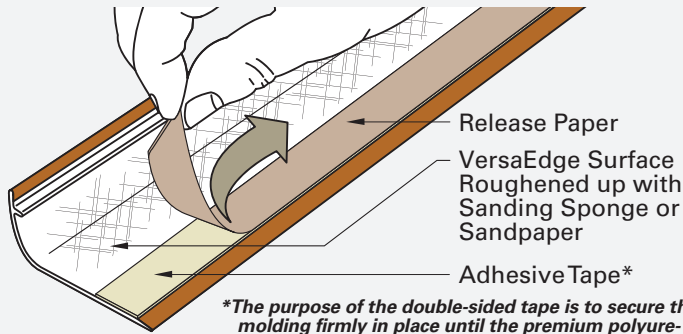
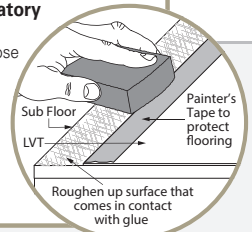

Step 2

Turn VersaEdge over and roughen the inside surface of the VersaEdge to increase bond by means of 60 grit sandpaper, sanding sponge, or a metal brush. Then, gently peel the release paper all the way off the adhesive tape.

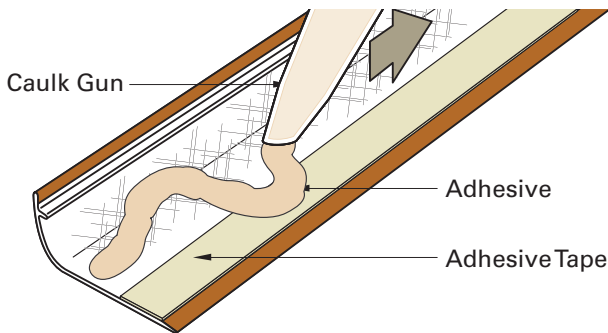

Step 3

Next, apply a generous bead of a **Premium Polyurethane Construction Adhesive** along the entire inside corner. **Be sure to overlap the tape with the adhesive.** Reveal edge of plank may show when VersaEdge is installed. To compensate, apply a little more adhesive to the molding.

Underside of molding generously covered with adhesive

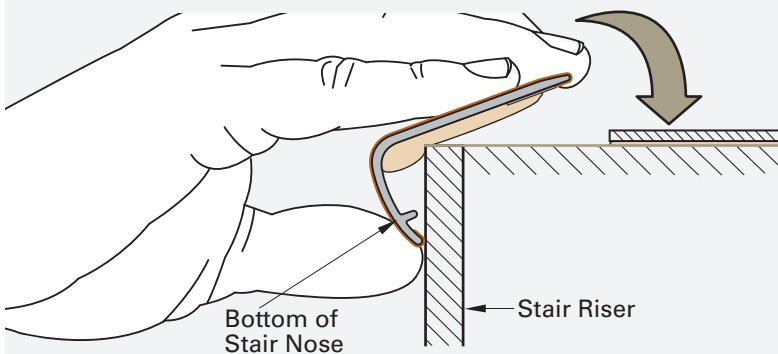
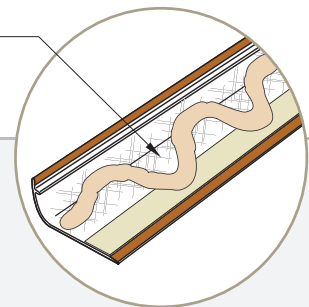

Step 4

Touch the bottom of molding to the stair riser and carefully roll the stair nose in place. Make any final adjustments before you push the molding all the way down. Once it's in the final position, press down firmly with your hands and make your way down the entire stair nose. It may take 2 or 3 passes to set it firmly in place.

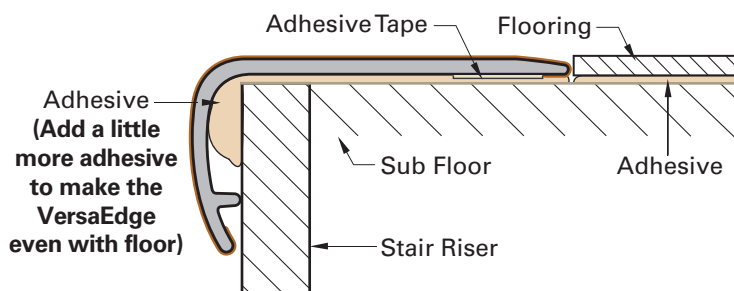

Step 5

The tape may not sufficiently adhere to the rougher stair or subfloor surfaces. **Allow at least 24 hours for the construction adhesive to form a bond.** You should always start at top of stairs and work your way down to avoid contact with the installed moldings until cured.

NOTE: Complete cure takes 48-72 hours.

“Flush Lock-Down” Installation

Flooring with an overall thickness of

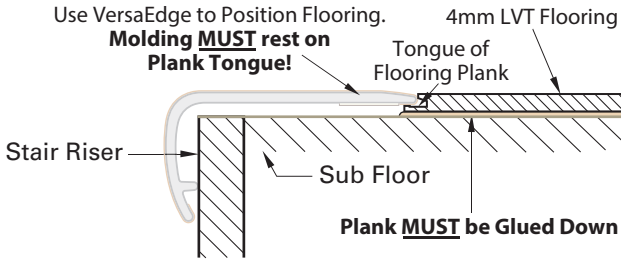

Step 1

Install the riser flush to the stair. Use VersaEdge to determine where to start your flooring. **Tongue side of flooring plank MUST face VersaEdge** so VersaEdge can fit snugly onto Tongue. Remove VersaEdge and **glue the flooring plank down**. Clean flooring and molding as directed below:

CLEANING PREPARATION FOR BOTH SURFACES

Preparing the floor & molding as outlined is mandatory to achieve the required bonding strength

1. Use a damp cloth (water only) to clean both surfaces of loose particles or surface films.
2. Roughen the surfaces with sandpaper (100-150 grit), sanding sponge or metal brush. For flooring, only roughen up area that will be covered (1.25" to 1.5").
3. Degrease both surfaces to remove all traces of oil, grease, dust, and fingerprints by using a solvent such as methyl ethyl ketone (MEK), acetone or isopropyl alcohol.
4. Let both surfaces dry thoroughly before applying adhesive.

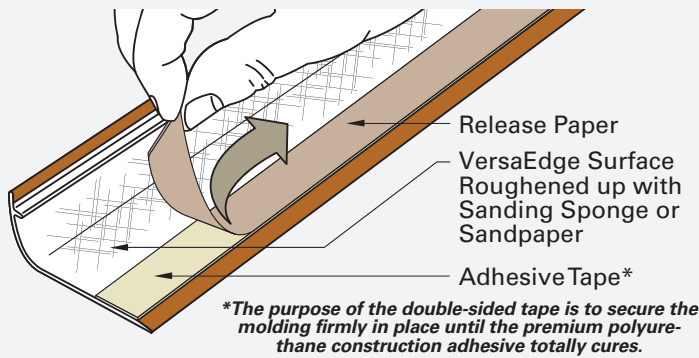
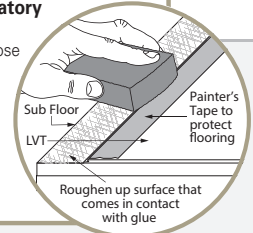

Step 2

Turn VersaEdge over and roughen the inside surface of the VersaEdge to increase bond by means of 60 grit sandpaper, sanding sponge, or a metal brush. Then, gently peel the release paper all the way off the adhesive tape.

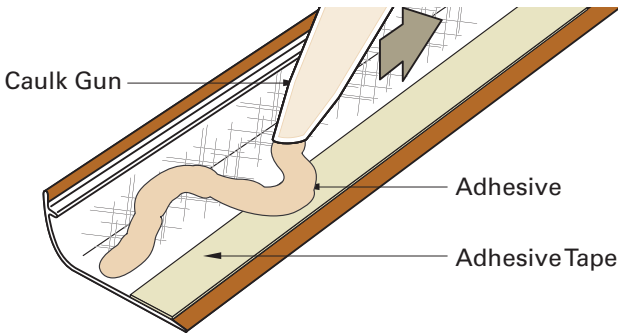

Step 3

Next, apply a generous bead of a **Premium Polyurethane Construction Adhesive** along the entire inside corner. **Be sure to overlap the tape with the adhesive.** Reveal edge of plank may show when VersaEdge is installed. To compensate, apply a little more adhesive to the molding.

Underside of molding generously covered with adhesive

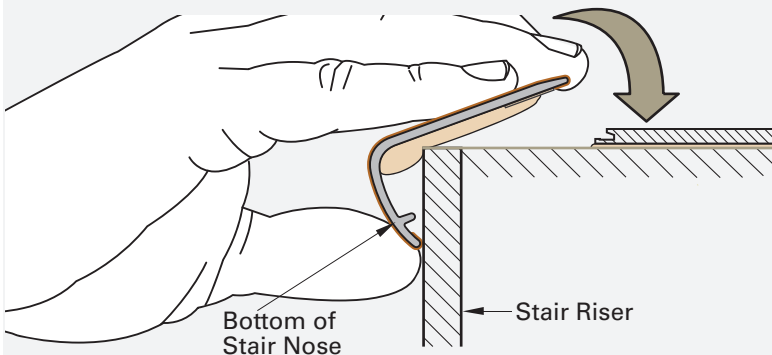
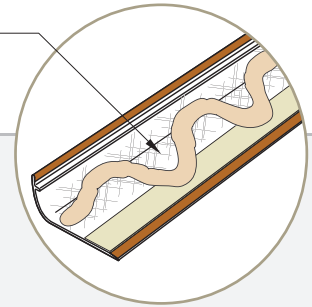

Step 4

Touch the bottom of molding to the stair riser and carefully roll the stair nose in place. Make any final adjustments before you push the molding all the way down. Once it's in the final position, press down firmly with your hands and make your way down the entire stair nose. It may take 2 or 3 passes to set it firmly in place.

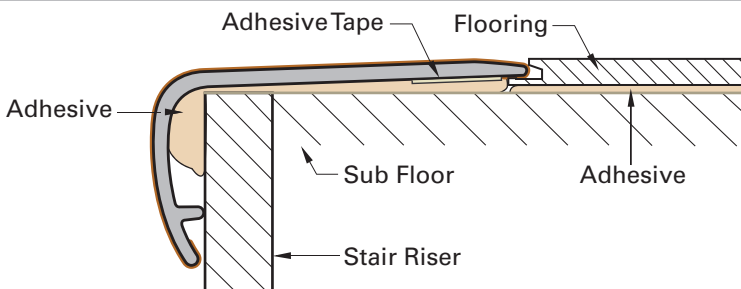

Step 5

The tape may not sufficiently adhere to the rougher stair or subfloor surfaces. **Allow at least 24 hours for the construction adhesive to form a bond.** You should always start at top of stairs and work your way down to avoid contact with the installed moldings until cured.

NOTE: Complete cure takes 48-72 hours.

“Flush Lock-Down” Installation

Flooring with an overall thickness of

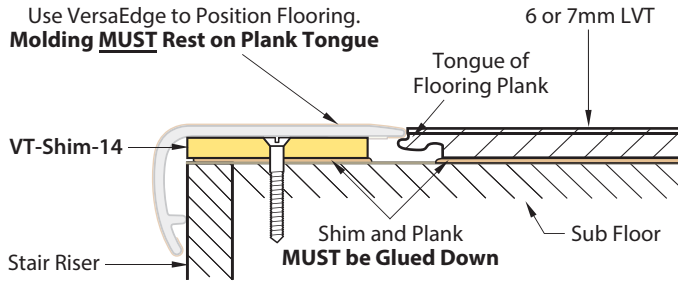

Step 1

Install the riser flush to the stair. Use VersaEdge to determine where to start your flooring. **Tongue side of flooring plank MUST face VersaEdge** so VersaEdge can fit snugly onto Tongue. Remove VersaEdge and **glue the flooring plank down**. Clean flooring and molding as directed below:

CLEANING PREPARATION FOR BOTH SURFACES

Preparing the floor & molding as outlined is mandatory to achieve the required bonding strength

1. Use a damp cloth (water only) to clean both surfaces of loose particles or surface films.
2. Roughen the surfaces with sandpaper (100-150 grit), sanding sponge or metal brush. For flooring, only roughen up area that will be covered (1.25" to 1.5").
3. Degrease both surfaces to remove all traces of oil, grease, dust, and fingerprints by using a solvent such as methyl ethyl ketone (MEK), acetone or isopropyl alcohol.
4. Let both surfaces dry thoroughly before applying adhesive.

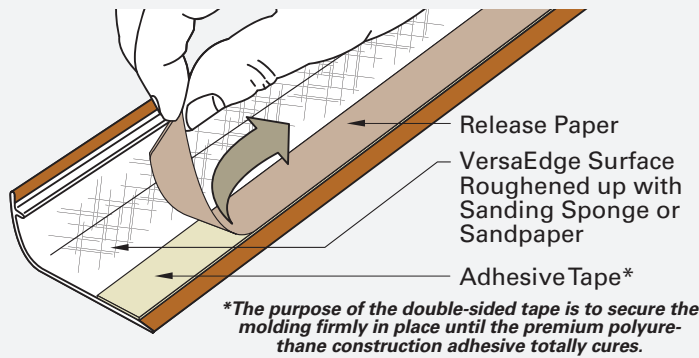
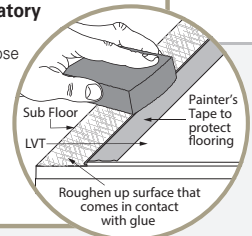

Step 2

Turn VersaEdge over and roughen the inside surface of the VersaEdge to increase bond by means of 60 grit sandpaper, sanding sponge, or a metal brush. Then, gently peel the release paper all the way off the adhesive tape.

Step 3

Next, apply a generous bead of a **Premium Polyurethane Construction Adhesive** along the entire inside corner. **Be sure to overlap the tape with the adhesive.** Reveal edge of plank may show when VersaEdge is installed. To compensate, apply a little more adhesive to the molding.

Underside of molding generously covered with adhesive

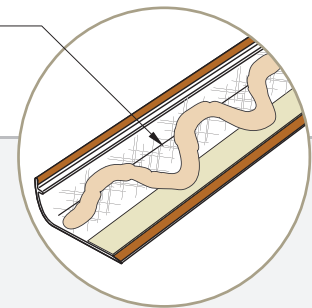

Step 4

Touch the bottom of molding to the stair riser and carefully roll the stair nose in place. Make any final adjustments before you push the molding all the way down. Once it's in the final position, press down firmly with your hands and make your way down the entire stair nose. It may take 2 or 3 passes to set it firmly in place.

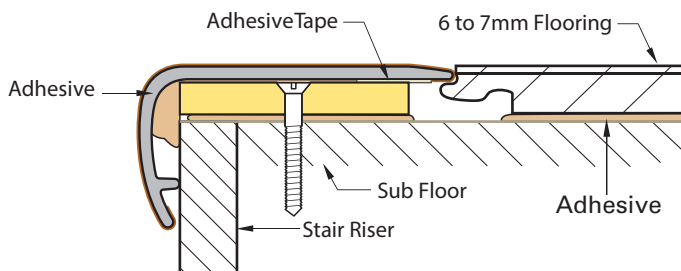
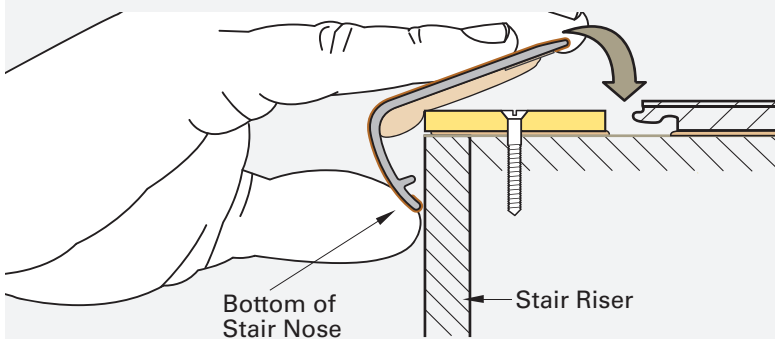
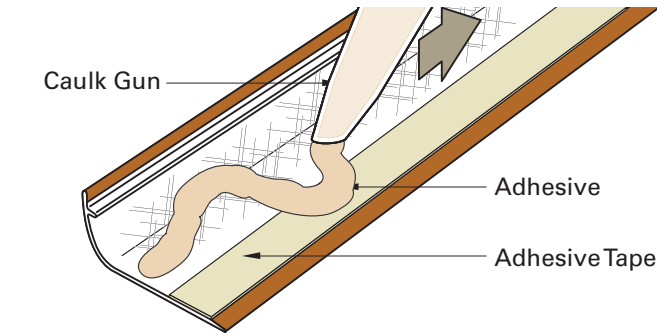

Step 5

The tape may not sufficiently adhere to the rougher stair or subfloor surfaces. **Allow at least 24 hours for the construction adhesive to form a bond.** You should always start at top of stairs and work your way down to avoid contact with the installed moldings until cured.

NOTE: Complete cure takes 48-72 hours.